

1" MECHANICAL FUEL METER

USER'S MANUAL



 **WARNING:** Read carefully and understand all **INSTRUCTIONS** before operating. Failure to follow the safety rules and other basic safety precautions may result in serious personal injury.

Item# 1581400

- **Be alert of your surroundings.** Using fuel meters in confined work areas may put you dangerously close to cutting tools and rotating parts.

PERSONAL SAFETY

- **Stay alert,** watch what you are doing and use common sense when operating a fuel meter. Do not use a fuel meter while you are tired or under the influence of drugs, alcohol or medication.
- **Dress properly.** Do not wear loose clothing, dangling objects, or jewelry. Keep your hair, clothing and gloves away from moving parts. Loose clothes, jewelry or long hair can be caught in moving parts. Air vents often cover moving parts and should be avoided.
- **Use safety apparel and equipment.** Use safety goggles or safety glasses with side shields which comply with current national standards, or when needed, a face shield. Use as dust mask in dusty work conditions. This applies to all persons in the work area. Also use non-skid safety shoes, hardhat, gloves, dust collection systems, and hearing protection when appropriate.
- **Do not overreach.** Keep proper footing and balance at all times.

INSTALLATION

1. The meter can be installed in any position, directly on rigid pipelines or flexible hoses, or directly on pumps or tanks.
2. The meter flow direction is fixed and indicated by an arrow. The meter is supplied in the standard configuration (Figure A).
3. The counter and the cover can be rotated around the body in order to carry out the different configurations (Figures B, C & D).
4. The reset knob can be installed either on the right side or on the left side of the meter in order to modify the standard configuration, following the instructions provided in the section “Disassembly/Reassembly.”
5. The meter body is equipped with 4 blind holes which can be threaded for a possible fastening. If solid particles enter the measuring chamber the correct working of the nutating disk may be affected.
6. Always filter the fluid by installing a filter (included) on the meter inlet.

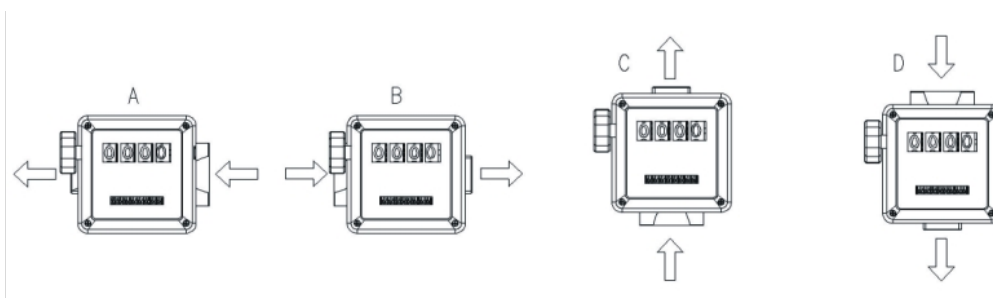

CALIBRATION

The meter is pre-calibrated in factory to be used with kerosene.

As specific operating conditions (such as real flow rate, nature and temperature of the measured fluid) may affect the meter accuracy, a recalibration should be carried out after the installation has been

completed. A new calibration is necessary each time the meter is disassembled for maintenance or when it is used to measure fluids other than kerosene.

CALIBRATION PROCEDURE

1. Unscrew the plug (see diagram, #26).
2. Purge the system (pump, pipelines & meter) of air by dispensing until the flow stream is full and steady.
3. Stop the flow by shutting off the nozzle, but let the pump continue to run.
4. Reset the batch register with the reset knob (#2).
5. Dispense at the most accurate flow rate, by using a calibrated container with a capacity of 5 gallons or more. Do not reduce the flow in order to reach the graduated zone of the calibrated container. Instead, use a “top-off” method, starting and stopping the full flow repeatedly until the required level is reached.
6. Compare the indication of the calibrated container (real value) with the meter’s indicated value.
 - a) If the indicated value is higher than the real value, loosen the screw (#24).
 - b) If the indicated value is lower than the real value, tighten the screw (#24).
7. Repeat the steps 4 to 6 until satisfactory accuracy is achieved.
8. Tighten the plug (#26) again. The O-ring (#23) provided with the calibration screw will hold the new calibration position to avoid accidental loosening of the adjustment screw but does not seal the unit, so it is always necessary to properly fix the plug (#26) with the sealing gasket (#25).

USE

After installation and calibration, the meter is ready to work.

Turn the reset knob (#2) clockwise if it is mounted on the left of the meter and counterclockwise if it is mounted on right, until the batch register is completely reset. The total register cannot be reset in any way.



WARNING: Make sure that during use pressure does not exceed 50 PSI.

GRAVITY-FED SYSTEMS

The meter can also be used in gravity-fed fuel units where the flow is generated by the difference in fuel level between the tank and the nozzle outlet. As a general rule, a gravity-fed system composed of a tank off the ground that has the meter installed at the bottom of the tank, using a 9.8-ft. long 1” flexible pipe, guarantees a flow rate of approximately 8 GPM if the height difference is greater than 5 feet. Longer pipes or nozzles producing higher pressure losses will reduce the flow rate.

NOTE: Use of this meter for gravity-fed systems with level differences less than 3 feet is not recommended because the reduced flow rate causes the meter to work outside its guaranteed accuracy range. Onsite calibration is required in any gravity-fed installation.

MAINTENANCE

No ordinary maintenance is required if the meter is properly installed and used according to

recommendations. An incorrect filtering on the meter inlet may block or wear out the measuring chamber, thus affecting the meter accuracy. Should this problem occur, disassemble the measuring chamber, as shown in section DISASSEMBLY/REASSEMBLY, and evaluate the filter's condition.



WARNING: Before disassembling the meter, always make sure that all fluid is drained from the meter and pipes connected with the meter.

User can carry out periodic cleaning of the unit with a soft brush or small tool (i.e. a screwdriver). During cleaning, be careful not to damage the chamber or the disk. Carefully check the meter and replace any damaged parts. Only use the original spare part kits (not included) shown in PART LISTS AND DIAGRAM.

NOTE: A new calibration is always necessary after cleaning or replacing the meter parts.

DISASSEMBLY/REASSEMBLY

The meter can disassemble easily into its primary components without removing the body from the pipes.

Meter unit

Disassemble the meter unit as follows:

1. Remove the reset knob by firmly pulling it straight out.
2. Loosen four retaining screws (#22).
3. Loosen two screws (#5).

To reassemble the unit, reverse the above procedure.

Measuring chamber

To enter the measuring chamber, operate as follows:

1. Disassemble the meter unit as the above steps 1-3.
2. Loosen the eight screws (#7).
3. Remove the body cover (#6), together with the gear unit.



WARNING: Be careful not to damage the sealing gasket (#16).

4. Remove the whole measuring chamber (#27) by lifting it from the meter body and at the same time pulling it back towards the inlet in order to remove the O-ring (#17) from its seat at the outlet.
5. Remove the O-ring (#17) and divide the measuring chamber (#27) into two half to check the inside of the chamber containing the nutating disk.

To reassemble the chamber, reverse the above procedure. Be sure to:

1. Verify that the nutating disk rotates freely in the assembled chamber.
2. Install the gaskets (#16, #17) properly after inspecting and lubricating them with grease.
3. Make sure that when reattaching the cover to the body of the meter, the nutating disk needle does not hit the driving lever (#14), which must remain free to be moved by the disk needle.

4. Tighten the screws (#7) completely.

Gear unit

To reach the gear unit components:

1. Remove the cover Assy. (#28).
2. Loosen the screws (#13).
3. Remove the plate (#12). Now all gears can be reached for inspection.
4. Should the gasket (#10) be replaced, remove the bevel gear (#8) from the shaft by pulling straight out, and then remove the gear unit (#11) together with the shaft.

To reassemble, reverse the above described procedure paying particular attention to:

1. Lubricating the O-ring with grease before installation.
2. Checking that the gear unit can rotate freely before reattaching the cover.

PARTS LIST AND DIAGRAM

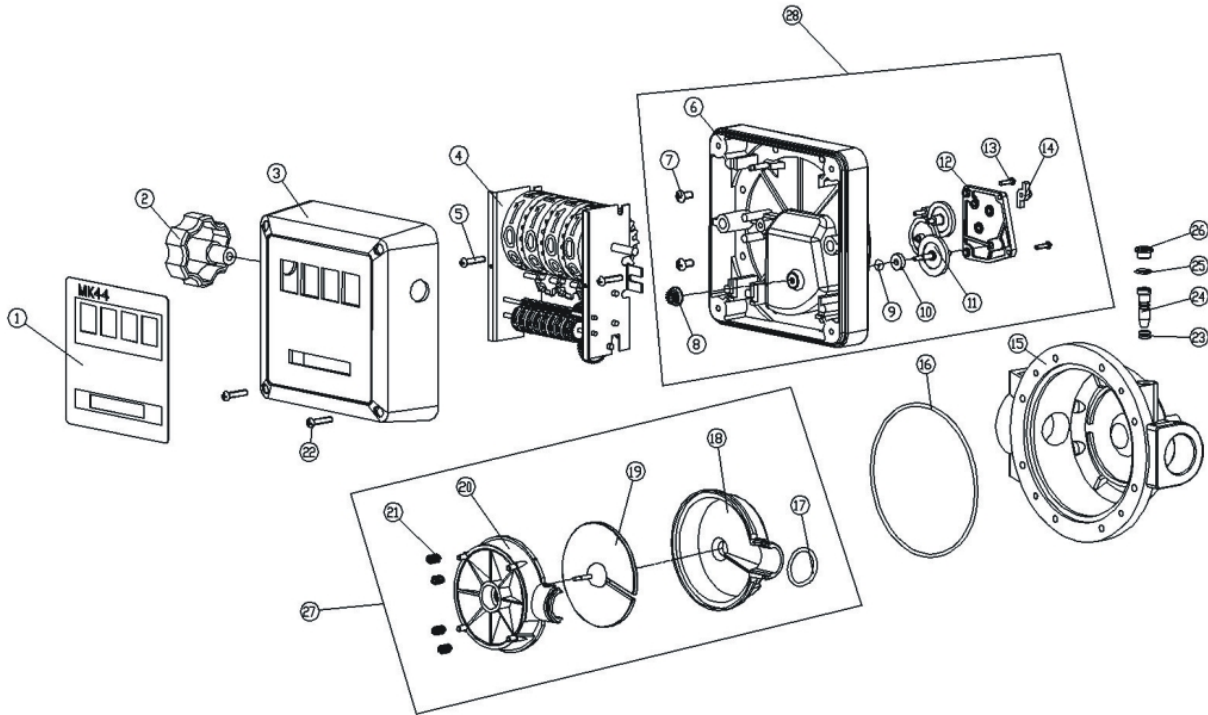

No.	Description	Quantity	No.	Description	Quantity
1	Name plate	1	15	Meter body	1
2	Reset knob	1	16	O-ring 110.72x3.53	1
3	External cover	1	17	O-ring 23.47x2.62	1
4	Meter	1	18	Measuring chamber	1
5	Screws 4x20	2	19	Measuring tray	1
6	Body cover	1	20	Measuring chamber	1
7	Screw 5x16	8	21	Cylinder spring	4
8	Bevel pinion	1	22	Screws 4x20	4
9	O-ring 3.62x2.62	1	23	O-ring 4.47x1.78	2
10	Cover sealing	1	24	By-pass adjusting screw	1
11	Gear kit	1	25	O-ring 9.25x1.78	1
12	Gear plate	1	26	By-pass plug	1
13	Screws 3x10	4	27	Measuring chamber Assy.	1
14	Driving lever	1	28	Body cover Assy.	1

If the meter is not working properly, contact an authorized service representative. Do not attempt to repair the meter yourself.